

## A Modified Type of the Resonant Turn-off SCR D-C Chopper\*

Toyoji HIMEI, Jyunichi INOUE and Kooichi FUKUMORI\*\*

*Department of Electrical Engineering*

(Received March 15, 1968)

A modified type of the resonant turn-off d-c chopper using an auxiliary SCR, compared with its conventional one, has no limitation about its starting and also operates more steadily. Presented in this paper, making a comparison between the modified type and the conventional one, are the circuit analysis and its efficiency measurement from the point of view of overall efficiency, that is, the ratio of the output to the input. Furthermore, some effects of the source impedance, counter emf load, etc. are discussed. As a result, it has been analytically clarified that this modified type is different from the conventional circuit only by one terminal connection of turn-off capacitor, but has the features of uncompounded circuit configuration, no limitation about its starting and more steady operation.

### § 1. Introduction

To control d-c voltage over wide voltage range from the source value to zero, it is desirable to use d-c chopper using SCRs because of their good efficiency, easy maintenance and containing no parts of wear and tear. There are many varieties of d-c chopper using SCRs. Above all, it seems to have been widely known that the conventional circuit of the resonant turn-off d-c chopper with an auxiliary SCR.<sup>1,2)</sup> This basic type has a fault about starting the operation. A modified version<sup>3,4)</sup> of the basic circuit which can be accomplished simply by transferring the one terminal of turn-off capacitor of the basic type to minus polarity of the source voltage, has no limitation about its starting and also operates steady. The modified circuit gives steady operation with not only an inductive load (resistive load with a smoothing reactor in series) but also a counter emf load.

In this paper on the modified type, making a comparison between the modified type and the basic one, the theory of operation will be made clear and the circuit analysis is given

\* Presented at the Annual Meeting of I. E. E. of Japan, Chugoku District, Nov. (1966) 121, Apl. (1967) 755, and the 10th Annual Conference of the Japan Association of Automatic Control Engineers, Nov. (1967)

\*\* Kurashiki Technical High School

and an efficiency measurement as overall efficiency, that is, the ratio of the output to the input. Furthermore, some considerations will be made about effects of the source impedance, counter emf load, etc.

### § 2. Circuit and Its Operation Theory

A modified type of the resonant turn-off d-c

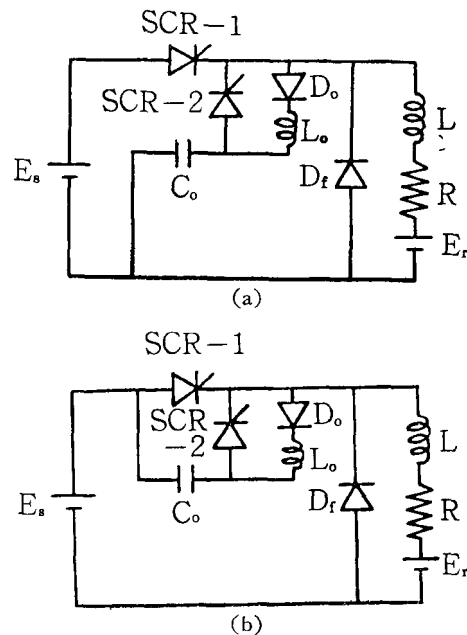

Fig. 1. Circuits of resonant turn-off SCR d-c chopper.

(a) modified type (b) basic circuit

chopper using an auxiliary SCR, as shown in Fig. 1 (a), is the circuit with one terminal of turn-off capacitor of the basic circuit (shown in Fig. 1 (b)) transferred to minus polarity of the source. In this circuit, when the SCR-1 is turned on, the current flowing through the SCR-1 is the sum of the load current and the resonant current which flows through  $D_0$ ,  $L_c$ ,

and  $C_0$ . The resonant current charges the turn-off capacitor up to the voltage  $2E_s$  and then falls to zero. The SCR-1 continues afterward to flow yet the load current. As soon as the SCR-2 is gated on, the difference between the capacitor voltage  $v_{co}=2E_s$  and the source voltage  $E_s$  appears across the SCR-1 in the negative anode-cathode direction and turns the SCR-1 off. At the same time, the voltage  $v_{co}$  starts to discharge through the load branch. When  $v_{co}$  drops to zero, the load current will flow the free-wheeling diode  $D_f$  until the SCR-1 will be gated on again. After that, this operation will be repeated.

In the basic circuit, at starting it is necessary to charge the turn-off capacitor up to the source voltage  $E_s$  by turning the SCR-2 on first. This process is the most fatal fault of the basic circuit. On the other hand, this modified type needs no such starting preparation.

Theoretical waveforms of the modified circuit are shown in Fig. 2.

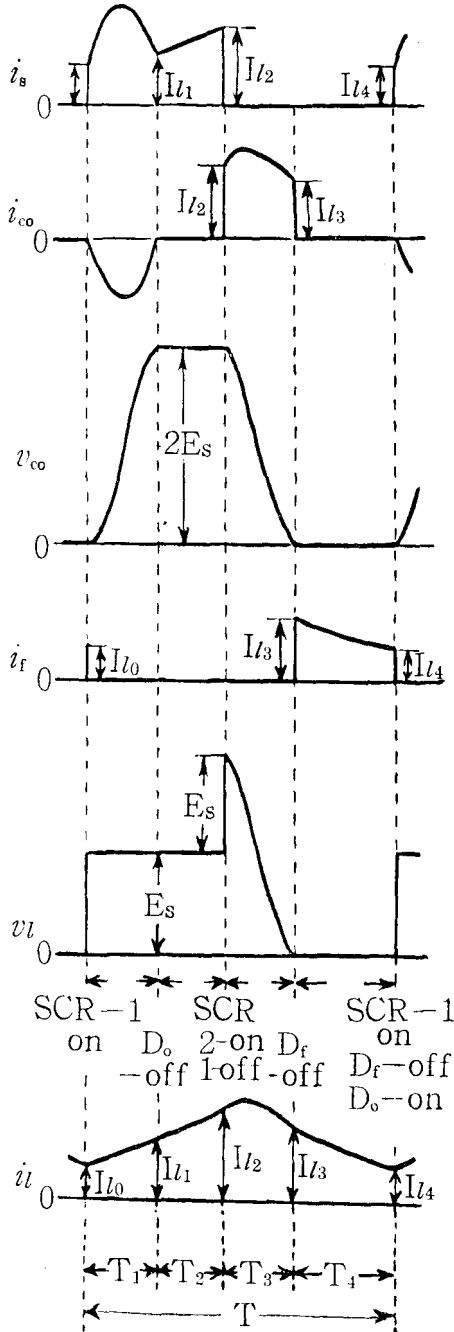

Fig. 2. Theoretical waveforms of the modified type.

### § 3. Analysis of Operation

To simplify the analysis of operation, it is assumed that the circuit operates under ideal conditions and also the semiconductor devices have the ideal characteristics, that is, the source impedance is negligible, forward voltage drops of the semiconductor devices are negli-

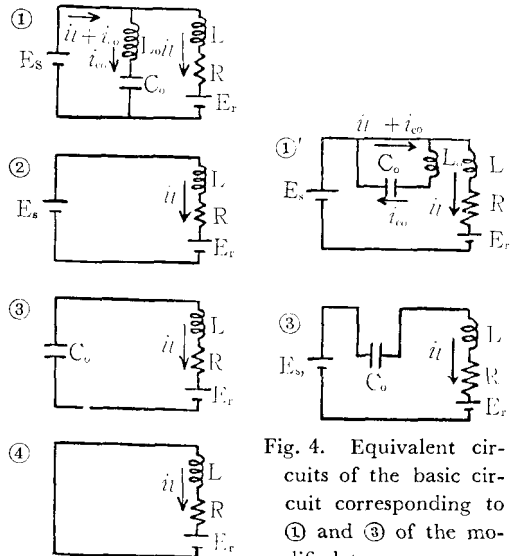

Fig. 3. Equivalent circuits of the modified type.

Fig. 4. Equivalent circuits of the basic circuit corresponding to ① and ③ of the modified type.

gible and also turn-on and turn-off time is zero.

The equivalent circuits of this modified type are shown in Fig. 3 and those of the basic circuit different from the modified type are in Fig. 4. The analysis of the modified type will be made in followings according to each modes of operation.

(3.1) *Interval T<sub>1</sub>* The equivalent circuit of this interval is indicated in Fig. 3 ①. The equation of the circuit will be set up as follows. Over  $0 \leq t \leq T_1$ ,

$$L \frac{di_l}{dt} + Ri_l + E_r = E_s \quad (1)$$

$$L_0 \frac{di_{co}}{dt} + \frac{1}{C_0} \int i_{co} dt = E_s \quad (2)$$

where boundary conditions are assumed as shown in Fig. 2. Using initial conditions at  $t=0$ ,  $i_{co}(0)=0$ ,  $v_{co}(0)=0$  and  $i_l(0)=I_{l0}$ , Eqs. (1) and (2) may be solved as follows.

$$i_l(t) = \frac{E_s - E_r}{R} (1 - \epsilon^{-\frac{t}{\tau_l}}) + I_{l0} \epsilon^{-\frac{t}{\tau_l}} \quad (3)$$

$$i_{co}(t) = \frac{E_s}{\omega_0 L_0} \sin \omega_0 t \quad (4)$$

$$v_{co}(t) = E_s (1 - \cos \omega_0 t) \quad (5)$$

where  $\omega_0 = \frac{1}{\sqrt{L_0 C_0}}$ ,  $\tau_l = \frac{L}{R}$

The time  $T_1$  when the resonant current  $i_{co}(t)$  comes to zero, will be derived by using Eq. (4).

$$\omega_0 T_1 = \pi, \therefore T_1 = \sqrt{L_0 C_0} \pi \quad (6)$$

At  $t=T_1$ , the voltage of turn-off capacitor  $v_{co}(T_1)$  and also  $i_l(T_1)$  are given as follows.

$$v_{co}(T_1) = 2E_s \quad (7)$$

$$i_l(T_1) = I_{l1} = \frac{E_s - E_r}{R} (1 - \epsilon^{-\frac{T_1}{\tau_l}}) + I_{l0} \epsilon^{-\frac{T_1}{\tau_l}} \quad (8)$$

Here, if the resistance  $R_0$  contained in the inductance  $L_0$  are taken into account, the equation of the circuit in terms of  $i_{co}(t)$  is as follows.

$$L_0 \frac{di_{co}}{dt} + R_0 i_{co} + \frac{1}{C_0} \int i_{co} dt = E_s \quad (2)'$$

From Eq. (2)',

$$i_{co}(t) = \frac{E_s}{\omega'_0 L_0 \sqrt{1 - \zeta_0'^2}} \epsilon^{-\zeta_0' \omega'_0 t} \sin \omega'_0 \sqrt{1 - \zeta_0'^2} t \quad (4)'$$

$$v_{co}(t) = E_s - E_s \epsilon^{-\zeta_0' \omega'_0 t} (\cos \omega'_0 \sqrt{1 - \zeta_0'^2} t + \frac{\zeta_0'}{\sqrt{1 - \zeta_0'^2}} \sin \omega'_0 \sqrt{1 - \zeta_0'^2} t) \quad (5)'$$

where  $\zeta_0' = \frac{R_0}{2} \sqrt{\frac{C_0}{L_0}} < 1$ ,  $\omega'_0 = \frac{1}{\sqrt{L_0 C_0}}$

The time  $T_1'$  at which  $i_{co}(t)$  becomes zero is given by Eq. (4)'.

$$T_1' = \frac{\pi}{\omega_0 \sqrt{1 - \zeta_0'^2}} \quad (6)'$$

At  $t=T_1'$ ,  $v_{co}(T_1')$  is,

$$v_{co}(T_1') = E_s \left( 1 + \epsilon^{-\frac{\zeta_0'}{\sqrt{1 - \zeta_0'^2}} \pi} \right) \quad (7)'$$

(3.2) *Interval T<sub>2</sub>* From Fig. 3 ②, it is clear that the equation of the circuit is identical with Eq. (1) in the interval  $T_1$ . Its solution is also the same to that of Eq. (1) but the initial conditions at  $t=0$ ,  $i_l(0)=I_{l1}$ . Over  $0 \leq t \leq T_2$ ,

$$i_l(t) = \frac{E_s - E_r}{R} (1 - \epsilon^{-\frac{t}{\tau_l}}) + I_{l1} \epsilon^{-\frac{t}{\tau_l}} \quad (9)$$

Since, in the intervals  $T_1$  and  $T_2$ , the load current  $i_l(t)$  is continuous and flows through the same loop. Eq. (9) may be written over  $0 \leq t \leq T_1 + T_2 = T_2'$ ,

$$i_l(t) = \frac{E_s - E_r}{R} (1 - \epsilon^{-\frac{t}{\tau_l}}) + I_{l0} \epsilon^{-\frac{t}{\tau_l}} \quad (10)$$

At  $t=T_2'$ ,  $i_l(T_2')$  is

$$i_l(T_2') = I_{l2} = \frac{E_s - E_r}{R} (1 - \epsilon^{-\frac{T_2'}{\tau_l}}) + I_{l0} \epsilon^{-\frac{T_2'}{\tau_l}} \quad (11)$$

(3.3) *Interval T<sub>3</sub>* From Fig. 3 ③, the equation of the circuit is over  $0 \leq t \leq T_3$ ,

$$L \frac{di_l}{dt} + Ri_l + \frac{1}{C_0} \int i_l dt + E_r = 0 \quad (12)$$

Using initial conditions, at  $t=0$ ,  $i_{co}(0)=i_l(0)=I_{l2}$ ,  $v_c(0)=v_l(0)=v_{co}(T_1)$ , by Laplace transform Eq. (12) becomes

$$i_l(s) = \frac{v_{co}(T_1) - E_r}{L} \frac{1}{(s + \zeta_l \omega_l)^2 + \omega_l^2 (1 - \zeta_l^2)} + \frac{s I_{l2}}{(s + \zeta_l \omega_l)^2 + \omega_l^2 (1 - \zeta_l^2)} \quad (13)$$

where  $\zeta_l = \frac{R}{2} \sqrt{\frac{C_0}{L}}$ ,  $\omega_l = \frac{1}{\sqrt{LC_0}}$

The inverse transform of this equation is made

according to  $\zeta_i \leq 1$ , respectively.

(i)  $\zeta_i < 1$

$$i_i(t) = i_{co}(t) = \frac{v_{co}(T_1) - E_r}{\omega_i L \sqrt{1 - \zeta_i^2}} \varepsilon^{-\zeta_i \omega_i t} \sin \omega_i \sqrt{1 - \zeta_i^2} t + I_{i2} \varepsilon^{-\zeta_i \omega_i t} \left( \cos \omega_i \sqrt{1 - \zeta_i^2} t - \frac{\zeta_i}{\sqrt{1 - \zeta_i^2}} \sin \omega_i \sqrt{1 - \zeta_i^2} t \right) \quad (14)$$

$$v_i(t) = v_{co}(t) = (v_{co}(T_1) - E_r) \varepsilon^{-\zeta_i \omega_i t} \times (\cos \omega_i \sqrt{1 - \zeta_i^2} t + \frac{\zeta_i}{\sqrt{1 - \zeta_i^2}} \sin \omega_i \sqrt{1 - \zeta_i^2} t) - \frac{\omega_i L}{\sqrt{1 - \zeta_i^2}} I_{i2} \varepsilon^{-\zeta_i \omega_i t} \sin \omega_i \sqrt{1 - \zeta_i^2} t + E_r \quad (15)$$

(ii)  $\zeta_i = 1$

$$i_i(t) = i_{co}(t) = \frac{v_{co}(T_1) - E_r}{L} t \varepsilon^{-\omega_i t} + I_{i2} (1 - \omega_i t) \varepsilon^{-\omega_i t} \quad (14)'$$

$$v_i(t) = v_{co}(t) = (v_{co}(T_1) - E_r) \varepsilon^{-\omega_i t} (1 + \omega_i t) - \frac{I_{i2}}{C_0} t \varepsilon^{-\omega_i t} + E_r \quad (15)'$$

(iii)  $\zeta_i > 1$

$$i_i(t) = i_{co}(t) = \frac{v_{co}(T_1) - E_r}{\omega_i L \sqrt{\zeta_i^2 - 1}} \varepsilon^{-\zeta_i \omega_i t} \sinh \omega_i \sqrt{\zeta_i^2 - 1} t + I_{i2} \varepsilon^{-\zeta_i \omega_i t} (\cosh \omega_i \sqrt{\zeta_i^2 - 1} t - \frac{\zeta_i}{\sqrt{\zeta_i^2 - 1}} \sinh \omega_i \sqrt{\zeta_i^2 - 1} t) \quad (14)''$$

$$v_i(t) = v_{co}(t) = (v_{co}(T_1) - E_r) \varepsilon^{-\zeta_i \omega_i t} \times (\cosh \omega_i \sqrt{\zeta_i^2 - 1} t + \frac{\zeta_i}{\sqrt{\zeta_i^2 - 1}} \sinh \omega_i \sqrt{\zeta_i^2 - 1} t) - \frac{\omega_i L}{\sqrt{\zeta_i^2 - 1}} I_{i2} \varepsilon^{-\zeta_i \omega_i t} \sinh \omega_i \sqrt{\zeta_i^2 - 1} t + E_r \quad (15)''$$

(3.4) *Interval  $T_4$*  The equation of the circuit in this interval are set up by referring to Fig. 3 ④ over  $0 \leq t \leq T_4$

$$L \frac{di_i}{dt} + Ri_i + E_r = 0 \quad (16)$$

Using initial conditions at  $t=0$ ,  $i_i(0) = I_{i3}$ , Eq. (16) may be solved as follows.

$$i_i(t) = I_{i3} \varepsilon^{-\frac{t}{\tau_i}} - \frac{E_r}{R} (1 - \varepsilon^{-\frac{t}{\tau_i}}) \quad (17)$$

$$v_i(t) = 0$$

The load current, at  $t = T_4$ , is as follows.

$$i_i(T_4) = I_{i4} = I_{i3} \varepsilon^{-\frac{T_4}{\tau_i}} - \frac{E_r}{R} (1 - \varepsilon^{-\frac{T_4}{\tau_i}}) \quad (18)$$

(3.5) *Average Value of Load Current* The

average value of the load current in a cycle will be derived from Eqs. (10), (14) and (17) as follows.

$$I_{ave} = \frac{1}{T} \left[ \frac{E_s - E_r}{R} \left\{ T_2 - \tau_i (1 - \varepsilon^{-\frac{T_2}{\tau_i}}) \right\} + \tau_i I_{i0} (1 - \varepsilon^{-\frac{T_2}{\tau_i}}) + \frac{I_{i2}}{\omega_i \sqrt{1 - \zeta_i^2}} \sin \omega_i \sqrt{1 - \zeta_i^2} T_3 \varepsilon^{-\zeta_i \omega_i T_3} - \frac{v_{co}(T_1) - E_r}{\omega_i^2 L} \left\{ (\cos \omega_i \sqrt{1 - \zeta_i^2} T_3 + \frac{\zeta_i}{\sqrt{1 - \zeta_i^2}} \sin \omega_i \sqrt{1 - \zeta_i^2} T_3) \varepsilon^{-\zeta_i \omega_i T_3} - 1 \right\} + \tau_i I_{i3} (1 - \varepsilon^{-\frac{T_4}{\tau_i}}) - \frac{E_r}{R} \left\{ T_4 - \tau_i (1 - \varepsilon^{-\frac{T_4}{\tau_i}}) \right\} \right] \quad (19)$$

where the load current in Interval  $T_3$  is supposed to be at  $\zeta_i < 1$ .

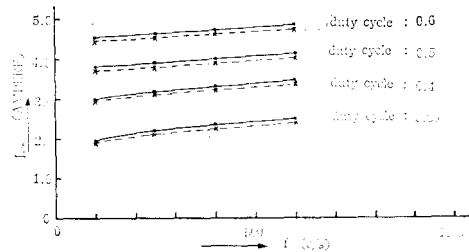

Fig. 5. Average values of load current. — — the calculated, —x— the measured

Examples of the calculated of the average value are shown in Fig. 5 in comparison with the measured. Here, counter emf  $E_r$  is taken zero and the resistance  $R_0$  of the inductance  $L_0$  are taken into account. The calculated agree fairly good with the measured.

The operation of the basic circuit is different from that of this modified type in Intervals  $T_1$  and  $T_3$  as shown in Figs. 3 and 4. Under ideal conditions in which the source impedance is negligible, the similar circuit analysis is applicable but is omitted here.

#### § 4. Experiment

##### (4.1) *Auxiliary Circuit*

The auxiliary circuit for gate inputs of the SCRs is shown in Fig. 6, composed of three main parts, that is, pulse generation, delay-amplification and Schmitt circuit for wave shaping.

The pulse frequency and the interval of

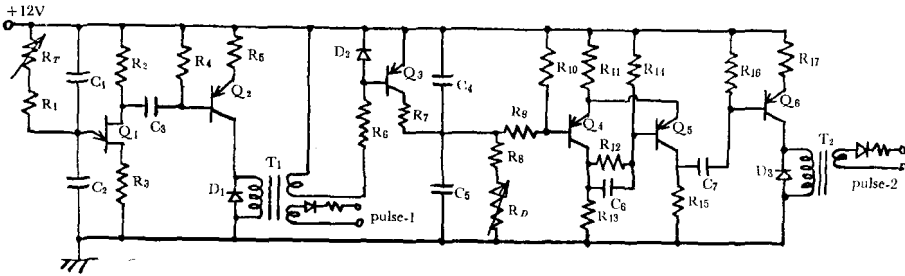

Fig. 6. Auxiliary circuit.

Table 1. Control characteristics of the auxiliary circuit.

Description	Rating
Output voltage	9 V
Frequency range	60~4, 500 c/s
Rise time	0.8 $\mu$ sec
Pulse width	32 $\mu$ sec
Minimum time interval between pulses 1 and 2	75 $\mu$ sec

pulses 1 and 2 are controlled by adjusting  $R_T$  and  $R_p$ , respectively. The control characteristics of this circuit are shown in Table 1. By use of this circuit, the frequency control and constant on-time control of the d-c chopper are possible and furthermore the constant off-time control is also possible by reversing the sequence of pulses 1 and 2.

(4.2) Steady State Performance

The waveforms of each branch when the armature of the d-c shunt motor were controlled by the d-c choppers of this modified type and of basic one, are shown in Fig. 7 (a) and (b), respectively. The source voltage  $E_s$  were 100V and the field windings of the d-c motor was excited by the separate source. The waveforms of the source current  $i_s$  and the voltage of the turn-off capacitor  $v_{co}$  of the modified type, are different from the counterparts of the basic circuit but the others are similar so closely.

(4.3) Transient Performance

The transient waveforms of the load voltage  $v_l$  and current  $i_l$  in both circuits are shown in Fig. 8 (a) and (b). They were observed by operating on the same conditions to steady state performance. In this transient performance, too, the waveforms of the modified type are similar to those of the basic one and suggest rapid response.

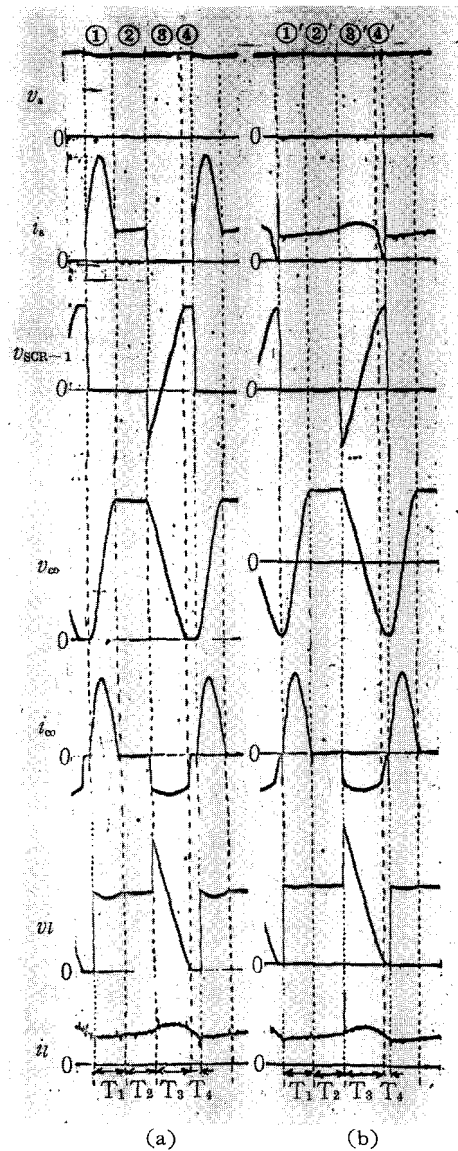

Fig. 7. Waveforms of each branch. (a) modified (b) basic

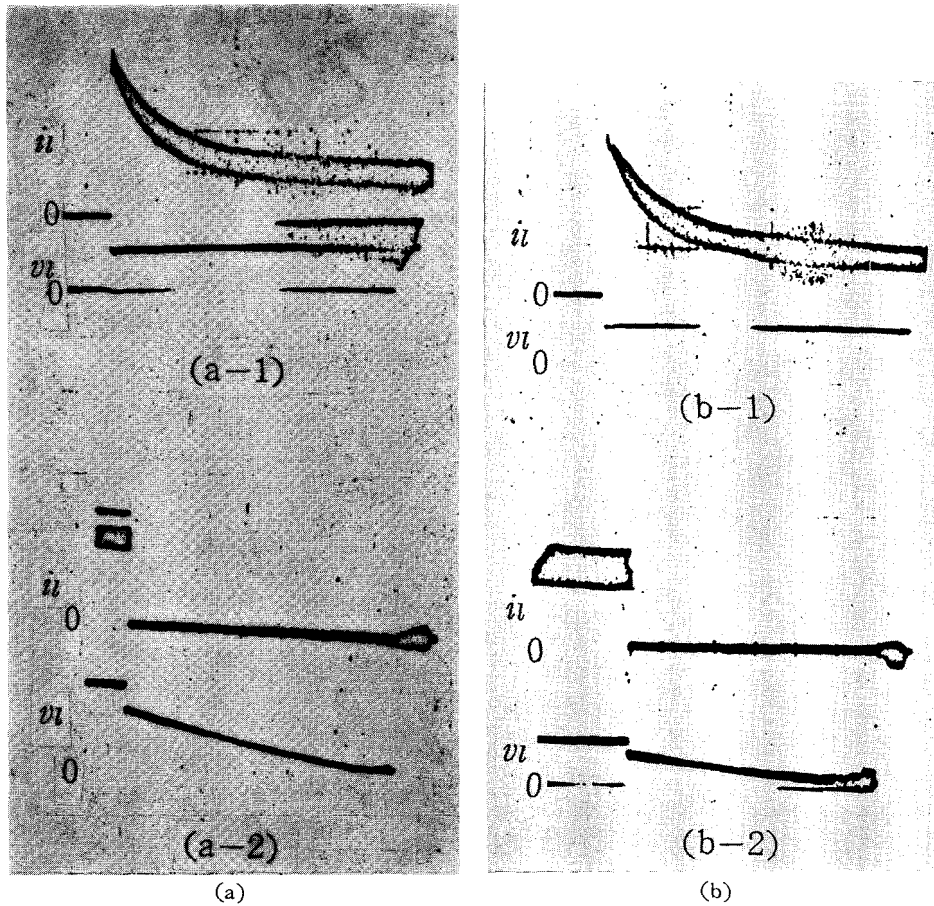

Fig. 8. Transient waveforms.

(a-1) at starting and (a-2) interrupting of the modified type, (b-1) at starting and (b-2) interrupting of the basic circuit

#### (4.4) Efficiency Measurement<sup>5)</sup>

Since the d-c chopper controls the output by interrupting the load current, the source current and the load voltage particularly, result in the periodically interrupted waveforms. The power measurement in the circuit where the discontinuous current flows, even if the high precision type wattmeter is used, includes errors fairly.<sup>6)</sup> Furthermore, owing to the limited frequency response of the wattmeter (1,000 c/s; one of electrodynamic type wattmeter), it should have to be considered that the errors will advance with frequency. In order to measure the power of the distorted waveforms, the most high precision is expected by calculating the power with the waveforms of the voltage and current. This means, however, is too troublesome to be practical.

The efficiency curves, measured with electrodynamic type wattmeter and calculated

with the voltage and current waveforms, are shown in Fig. 9(a). Though the absolute values of input and output contain considerable errors, the efficiency curves themselves agree with each other so closely that the efficiency measurement with the wattmeter gives a standard to a certain extent. The efficiency curves in Fig. 9(b) and (c) were measured with the electrodynamic type wattmeter.

In both the modified and basic circuits, the losses are mainly composed of; (i) the losses due to voltage drop of the SCR-1 and free-wheeling diode, (ii) the switching loss of the SCR-1 and (iii) the loss due to the charge and discharge in the resonant circuit. The efficiency characteristics with the same circuit constants, keeping the load current constant, as shown in Fig. 9(b), is inversely proportional to frequency. This is attributed to the increase of the loss of the charge and discharge in the

resonant circuit, because losses due to the voltage drops of the SCR-1 and  $D_T$  may be considered to be constant. In Fig. 9 (c) are shown the cases of the different circuit constants between each other but the invariable circuit constant control. These curves imply the

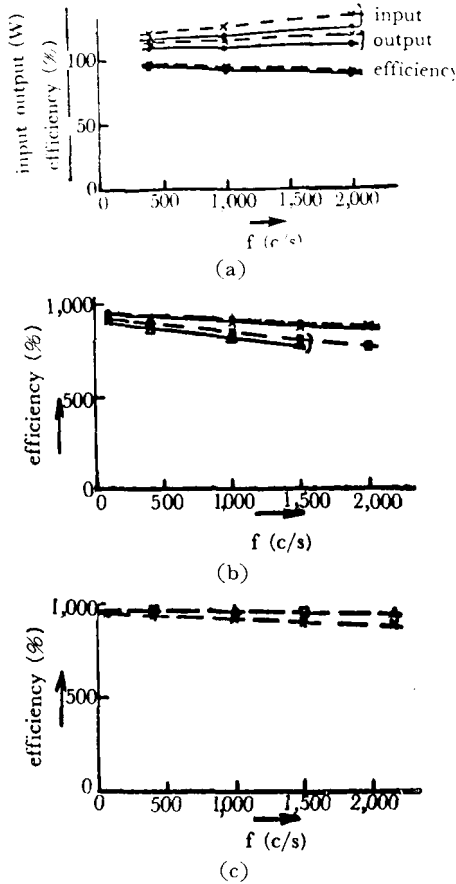

Fig. 9. Efficiency measuring.

(a) comparison of measuring methods with the modified type

--- measured with wattmeter, ---x--- calculated with waveforms

$E_s=50\text{ V}$ ,  $I_{ave}=4.0\text{ A}$ ,  $L=115\text{ mH}$ ,  $R=6.7\ \Omega$ ,  $L_0=318\ \mu\text{H}$ ,  $C_0=4\ \mu\text{F}$

(b) efficiency vs. frequency: different load current

---x--- 4.0A, ---o--- 2.5A on the modified type

---•--- 4.0A, ---□--- 2.5A on the basic circuit

the same circuit constants to those of (a)

(c) efficiency vs. frequency: different circuit constant

load current  $I_{ave}=4.0\text{ A}$

---•---(modified), ---x---(basic)

$E_s=50\text{ V}$ ,  $L=15\text{ mH}$ ,  $R=6.7\ \Omega$ ,  $L_0=318\ \mu\text{H}$ ,  $C_0=4\ \mu\text{F}$

---o---(modified), ---□---(basic)

$E_s=50\text{ V}$ ,  $L=303\text{ mH}$ ,  $R=10.7\ \Omega$ ,  $L_0=810\ \mu\text{H}$ ,  $C_0=1.9\ \mu\text{F}$

more close agreement of the efficiency of the modified type and basic one with the increased duty cycle.

§ 5. Discussion

(5.1) Effects of the Source Impedance

As previous mentioned, under the ideal circuit conditions, the difference of operations of two circuits does not exist virtually. When the source impedance  $L_s$  is not negligible, at turning-off of the SCR-1, the load current in the modified type will not be transformed from the SCR-1 to SCR-2 instantly. Since the voltage  $v_{co}$  discharges in this interval, the reverse voltage across the SCR-1 decreases. This phenomenon will not happen in the basic circuit. However, when the source impedance is not negligible, the smoothing capacitor  $C_s$  is usually put into the source. If this capacitor is large enough, the operation of the circuit is the same to that of the negligible source impedance. Since  $C_s$  is usually finite, the voltage across  $C_s$  decreases in the conducting interval of the SCR-1 and increases in the nonconducting interval (See Fig. 10). Its frequency is determined by  $L_s$  and  $C_s$  and is  $f=1/2\pi\sqrt{L_sC_s}$ . In the basic circuit,  $v_{co}(T_1)$  is affected by the reduced voltage across  $C_s$  at SCR-2 turning-on and then is made small. This results in the reduced reverse voltage across the SCR-1 at the instant when the SCR-2 is turned on.

On the other hand, in this modified type, the turn-off capacitor is charged by the increased voltage of SCR-1 turning-on and is less subject to the voltage fluctuations across  $C_s$ .

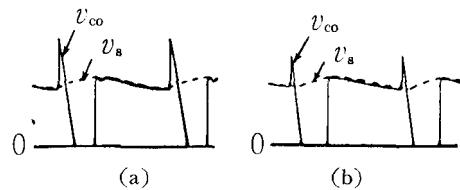

Fig. 10. Effects of the source impedance.

(a) modified type (b) basic circuit

(5.2) Counter Emf Load

When the chopper operates with the counter emf load and also the load current is discontinuous, as shown in Fig. 11, the counter emf  $E_r$  appears across the load in the nonconducting period of the SCR-1. In the basic circuit, the voltage  $v_{co}$  in this period is  $E_s-E_r$  and the reversed polarity one of this voltage causes the SCR-1 to turn off at the instant when the

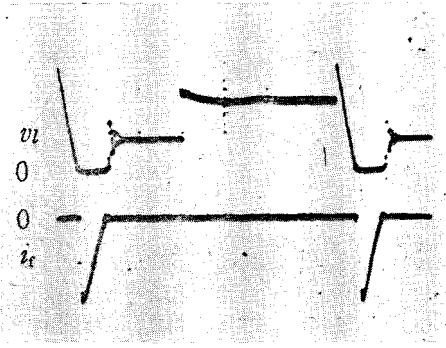

Fig. 11. Effects of discontinuous current due to counter emf load.

SCR-2 is turned on. This voltage is smaller than that of the continuous load current. In the modified type, the turn-off capacitor in this period is charged up to  $2E_r$  by the counter emf and is recharged more up to  $2(E_s - E_r)$  at the instant when the SCR-1 is turned on. Consequently, both circuits operate unstable or fail to operate under these conditions.

#### (5.3) Turn-off Capacitor

From the circuit arrangement of this modified type, it may be considered that the electrolytic capacitor with twofold withstand voltage will work as turn-off capacitor. According to authors' experience, however, it seems that the leakage of electrolytic capacitor makes the operation unstable.

#### (5.4) Efficiency Measurement

The efficiency measurement by a wattmeter of powers controlled by the d-c chopper contains fair errors because of the distorted wave-

forms and the limited frequency characteristics of the wattmeter. Since the ratio of errors of input and output, however, is nearly the same, the overall efficiency defined by the ratio of output to input gives a standard to a certain extent. The efficiency of the modified type does not differ virtually from that of the basic one but is somewhat small.

## § 6. Conclusion

As for the modified type have been presented, the circuit analysis, the efficiency measurement and discussions of effects of the source impedance, counter emf load, etc. It has been found that this modified type is different from the conventional circuit only by one terminal connection of turn-off capacitor, but has the features of uncompounded circuit configuration, no limitation about its starting and more stable operation.

## References

- 1) K. HEUMANN: IEEE Trans Commu. and Electronics **83**, (1964) No. 73, 390.
- 2) N. SATO: J. I. E. E. of Japan **87**, (1967) 398.
- 3) *Westinghouse SCR Designers' Handbook*, First Edition
- 4) T. HIMEI, J. INOUE and K. FUKUMORI: Annual Meeting of I. E. E. of Japan, Chugoku District, Nov. (1966) 121.
- 5) T. HIMEI, J. INOUE and K. FUKUMORI: Annual Meeting of I. E. E. of Japan, Chugoku District, Nov. (1967) 119.
- 6) M. S. ERLICKI, D. SCHIEBER and B. U. JOSEPH: IEEE Trans on Industry and General Applications IGA-2, (1966) No. 4, 309.