

*Engineering*  
*Mechanical Engineering fields*

---

Okayama University

Year 1999

---

Display of diagnostic information from  
multiple viewpoints in an anomalous  
situation of complex plants

Akira Gofuku  
Okayama University

Yutaka Tanaka  
Okayama University

This paper is posted at eScholarship@OUDIR : Okayama University Digital Information  
Repository.

[http://escholarship.lib.okayama-u.ac.jp/mechanical\\_engineering/30](http://escholarship.lib.okayama-u.ac.jp/mechanical_engineering/30)

# Display of Diagnostic Information from Multiple Viewpoints in an Anomalous Situation of Complex Plants

Akio Gofuku and Yutaka Tanaka  
Department of Systems Engineering, Okayama University  
3-1-1 Tsushima-Naka, Okayama, 700-8530, Japan  
fukuchan@sys.okayama-u.ac.jp

## ABSTRACT

This paper describes the objectives, approaches, and current status of an intelligent information display agent called semantic representation interface (SI). The SI displays diagnostic information from functional viewpoint as well as from behavioral, operational, and structural ones to plant operators in an anomalous situation. The functional information of plant will help operators to understand overall plant situation and the necessity of a recommended counter action written in operation manuals or suggested by the SI. Diagnostic information of anomaly identification and finding possible counter actions are derived by the qualitative reasoning based on a functional model. The selection of suitable counter actions which will be developed in a near future is made using a fast future prediction code generated by an intelligent modular simulation system. The derived diagnostic information is displayed in a graphical way such that an operator can understand the information as a pattern. In addition to the graphical display, necessary graphs to understand plant situation and the derived diagnostic information are automatically shown. The applicability of the diagnostic techniques applied the qualitative reasoning is discussed through applications to an oil refinery plant.

## 1. INTRODUCTION

The reliability and flexibility of plant control and diagnosis systems have recently enhanced by the quick advances of computer technology, artificial intelligence, digital control systems, and so on. The expected role of operators in an advanced plant is to take suitable counter actions in an unexpected event as well as to operate the plant in supposed plant operating conditions. The display technique of necessary information to help operator actions is very important to decrease human errors for the operation especially in an anomalous event. In other words, a useful human-machine interface is necessary to communicate quickly and suitably large information in an anomalous situation of plants.

The human cognitive characteristics in an emergency situation are discussed for each of information reading, information processing, and action executing stages[1]:

- (1) The characteristics in the information reading stage are persistence in only the measurements indicating anomalous condition, ignorance of the measurements indicating normal condition, and quality deterioration of information reading.
- (2) The characteristics in the information processing stage are quality deterioration in analyzing information, deciding action policy, and using memorized knowledge, and omission of the check of processed information.

- (3) The characteristics in the action executing stage are habitual action execution and mis-press of buttons.

In consideration of the human characteristics in an emergency situation, an information display interface system should indicate efficiently the necessary information[2]

- (1) to make operators not to be trapped in a cognitive narrow path,
- (2) to make up operators' cognitive resources (awareness and knowledge about plant) and to support the usage of the resources, and
- (3) to support to organize an accurate mental model of plant situation through multi-modal information display.

Vicente, et al.[3] proposes an information display technique called ecological interface, where invisible internal system information to be controlled is provided to operators in the form such that the indication style of information matches with operators' cognitive characteristics and the tasks to be executed. Another new concept to develop user-friendly interface systems is the adaptive interface concept[4].

The common information display systems like DCSs (distributed control systems) equipped in current plants offer only behavioral and structural information. Although such information is important to understand plant situation, the goal and purpose of counter actions specified in plant manuals or suggested by an operator support system are hard to understand due to the lack of information from an intentional aspect of plants. Therefore, the authors consider that a display system should indicate functional information of plants as well as behavioral, structural, and operational information. From the standpoint, the authors are studying an intelligent information display agent called semantic representation interface (SI)[5] to understand easily and precisely both plant conditions and effectiveness of counter actions in an emergency plant situation. The basic approaches of the SI are

- (i) modeling and usage of designers' intentions by a functional modeling framework in addition to the information of plant behaviors, structure, and operation procedures,
- (ii) generation of diagnostic information such as identification of anomaly cause, derivation of possible counter actions, and evaluation of the effects of a counter action by model-based reasoning, and
- (iii) application of the adaptive interface concept[4] to offer diagnostic information according to the information category which operators are paying attention to.

Functional information of plant will help operators to understand

overall plant situation and the necessity of a recommended counter action by the operation manuals or the SI because it expresses the reason and background of the existence of components. In this study, a function is defined as the selected and interpreted behavior from the point of system/component goal and role. The relevant functions and components with plant anomaly or a recommended counter action are displayed in a graphical way such that operators can quickly understand the information as a pattern. The diagnostic information such as anomaly identification and possible counter actions is derived by applying the qualitative reasoning based on a functional model. The qualitative reasoning resembles a human thinking to roughly examine, for example, the affection of a cause. Although it is difficult for the qualitative reasoning to deal with time, the inference results are easy to be explained by ordering the inference processes. A suitable application of the adaptive interface concept to slightly change the explanation order of diagnostic information is effective to make operators to remove from a cognitive narrow path although they may confuse in an excessive application of the concept. These features of the SI will lead the decrease of mis-operation and can make operators to monitor effectively the transition of plant condition after taking a counter action.

In the previous studies, a technique to derive possible counter actions was developed[6, 7]. A graphical interface system is developed to support the construction of the plant model[8] that expresses functional, behavioral, structural, and procedural information of plants. The authors also proposed an intelligent modular simulation technique[9] which will be implemented in the SI to evaluate a counter action.

The current study develops a technique to identify the anomaly cause from a set of candidates of anomaly causes. This paper describes the anomaly identification technique and objectives, approaches, and current status of the SI development. This paper also discusses applications of the developed diagnostic techniques to an oil refinery plant using a plant simulator.

## 2. SEMANTIC REPRESENTATION INTERFACE

The objectives to develop the SI is to suitably provide operators diagnostic information from multiple viewpoints to support plant operation in an anomalous situation. The SI is developed as an intelligent agent in an interface system[5] for a next generation plant. The SI will have the following capabilities:

- (1) identification of anomaly cause from a given set of candidates,
- (2) finding out possible counter actions,
- (3) evaluation of the suitability of a counter action from the viewpoints of both plant future conditions and plant design intentions, and
- (4) flexible indication of these diagnostic information according to operators' attention.

The characteristic feature of the SI is that it can display functional information as well as behavioral, operational, and structural ones.

The SI is composed of

- (a) plant model including the information of plant functions as well as the information of behaviors, structure, and operation actions,
- (b) identification subsystem of anomaly cause from a set of

- probable causes given by the interface agent (IA)[5] through a distributed agents system,
- (c) derivation subsystem[6, 7] of possible counter actions,
- (d) evaluation subsystem of the effects of a counter action, and
- (e) display control subsystem to flexibly indicate diagnostic information according to the operators' attention.

The plant model is based on a functional modeling framework, Multi-level Flow Modelling (MFM)[10], to express intentional information of plants, that is, goals and functions as well as structural information. The plant model also includes the information such as qualitative relations between goals and functions, operator actions and component behavior at the happening of an anomaly. The qualitative reasoning technique is applied to develop the subsystems (a) and (b). An intelligent modular simulation technique[9] is adopted to generate a simulation code to predict future trend of plant behavior in the subsystem (d).

Figure 1 shows the configuration of the SI and the relations among other intelligent agents, interface agent (IA) and ontology server (OS). The SI is implemented on a distributed multi-agents system using application program interfaces[5]. The SI actually starts its activity by the announcement of the detection of anomalous change of plant instrumentation signals from the IA. The SI graphically indicates functional, behavioral, and structural information of the anomalous signal change. Then, a list of the candidates of anomaly causes is given from the IA. The SI identifies the anomaly cause by the subsystem (b). After that, possible counter actions are derived by the subsystem (c). A suitable counter action is selected based on the evaluation results by the subsystem (d). The SI displays the diagnostic information by the subsystem (e). The OS plays an important role to communicate between the IA and the SI by serving suitable terms to understand each other the content of information generated by them.

## 3. PLANT MODEL REPRESENTING THE INFORMATION FROM MULTIPLE VIEWPOINTS

As previously mentioned, the plant model is based on the MFM[10]. The MFM is first introduced in this section.

The MFM is a methodology to model an engineering system from the standpoint of means and goals. The MFM represents intentional

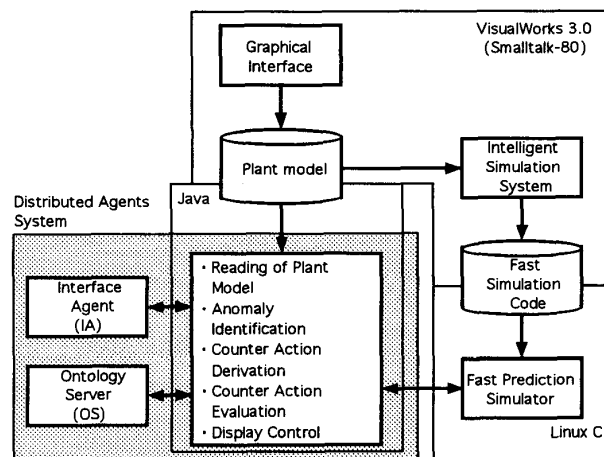

Fig. 1 Configuration of semantic representation interface and relation with other intelligent agents.

aspects of a system from the standpoint that a system is an artifact, that is, a man-made purposeful system. The MFM models a system in two dimensions. The relation among system goals, sub-goals, and system functions to achieve goals/sub-goals is represented by the means-end dimension. The MFM also represents a system in a whole-part dimension, that is, a system is represented by a multiple of descriptions on different levels of aggregation.

The MFM defines a function as a useful behavior. The definition is similar to that of this study. System functions are represented by a set of mass, energy, activity, and information flow substructures on several levels of abstraction. Mass and energy flow substructures model system functions, while activity and information flow substructures model operator actions and control system functions. Figure 2 shows the flow function concepts (excluding control functions) and their associated symbols in mass and energy flow substructures. The authors add the energy conversion function to model a mechanical system as well as process plants studied in the original MFM. Using these concepts, it is possible to represent knowledge of a system which one can capture the intentions of designers of plant and its control systems.

The plant model used in this study also contains the following six kinds of knowledge in addition to the MFM model. Table 1 summarizes the knowledge. By adding the knowledge, the plant model includes functional, behavioral, structural, and operational aspects of a plant.

The knowledge B-knowledge expresses the behavior that is not a function but sometimes plays important role in the management of an anomalous situation. This knowledge is used to find alternative counter actions. The qualitative relation among goals/sub-goals and functions is represented by AL-G-knowledge and G-F knowledge. An associative link (AL) is defined as two neighboring functions that play direct role to achieve the goal by the flow structure containing the AL. The AL-G-knowledge represents a qualitative relation of the change of flow through the AL to the achievement of the goal. Similarly, G-F-knowledge expresses the influence of the change of goal achievement to the state of the function conditioned by the goal. The relation between available counter actions and the behaviors of controlled components is called as O-knowledge. If there are some actions that should not be made in the normal operational procedure but can be made in an

Table 1 Knowledge included in plant model in addition to a MFM model

Knowledge type	Content
B-knowledge	. System behaviors which do not contribute to any system goal (subgoal)
AL-G-knowledge	. Link of two functions (associative link) in a flow structure which directly contributes to the goal achieved by the flow structure . Influence to the achievement of the goal from the change of the flow at the associative link
G-F-knowledge	. Influence to the flow of function from the change of achievement of the conditional goal
O-knowledge	. Available operations and the behaviors of components controlled by the operations
CB-knowledge	. Behaviors of components when an anomaly happens in the components
D-knowledge	. Dangerous situations of plant

anomalous situation, these actions are also included in the O-knowledge. The component behavior knowledge (CB-knowledge) expresses the relation between an anomaly and the behavior of component when the anomaly happens. The knowledge about dangerous situations of plant components (D-knowledge) expresses a dangerous situation by pairs of quantities and their mathematical conditions.

#### 4. INFORMATION DISPLAY BY SEMANTIC REPRESENTATION INTERFACE

An example screen of the current version of the SI is shown in Fig. 3. The information of goals/sub-goals and functions and their relation is expressed in the function-goal layer shown in the upper left window. The structural information is shown as a plant system diagram in the structure layer as shown in the upper right window. In addition to these windows, a message window appears to indicate various messages to notify the results of anomaly identification, derivation of counter actions, and so on.

An anomalous change of a plant instrumentation signal is detected in the IA as an inexperienced change or is detected in the SI using an allowance level of the signal. Then, the SI shows the component(s) and function(s) related with the signal by changing the color of symbols to a warning color (red, orange, or yellow according to the change level). The SI also shows a suitable type of graph for the signal to indicate the anomalous change. Currently, there are four types of graphs, that is, trend graph, trend graph with prediction, x-y graph, and specific x-y graph to show pump characteristic curve. In Fig.3, examples of pump characteristic curve and trend graph are shown. The necessary data for the graph are obtained through the IA. The selection of graph type is based on the knowledge extracted to some anomaly scenarios. For example, when the operating condition of a pump changes, its current condition and normal characteristic curve of the pump are indicated as a specific x-y graph.

When the anomaly cause is identified or effective counter actions are found, the SI indicates the relevant component and the functional role of the component in structure and function-goal layers by changing their symbol colors. The SI announces the results of diagnosis to other agents with the help of the OS to select suitable sentence and words. The announcement is also indicated in the message window.

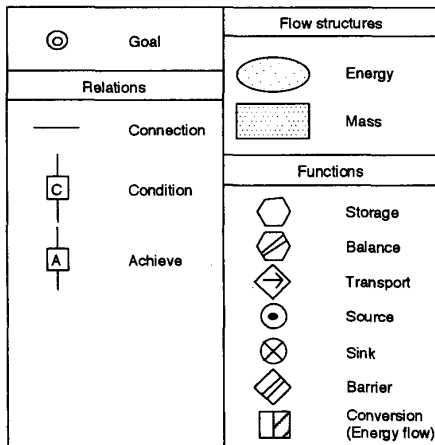

Fig. 2 Symbols to represent goals, functions, and their relations.

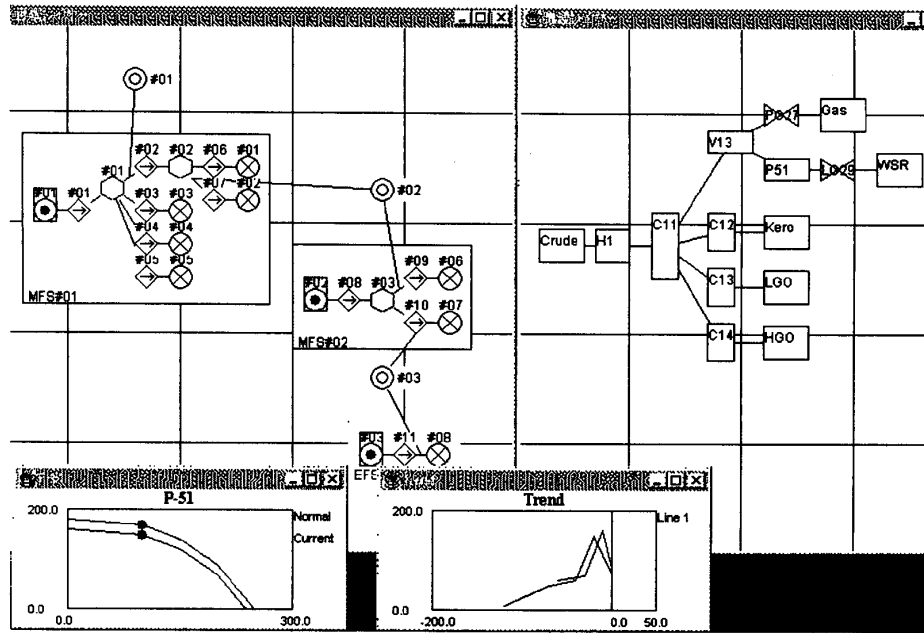

Fig. 3 Example screen indicated by semantic representation interface.

## 5. IDENTIFICATION OF ANOMALY CAUSE

There are three steps to identify anomaly cause from a set of candidates:

- deduction of influence of each anomaly cause in the set to plant functions and goals,
- evaluation of states of plant functions using plant instrumentation signals, and
- comparison of the results of the step (a) with those of the step (b).

In the deduction of anomaly influence, the location, type, and degree of each anomaly candidate are given. Figure 4 shows the outline of the deduction of anomaly. First, the anomaly is mapped to the corresponding function or behavior in the plant model by the component behavior knowledge (CB-knowledge) and the realization relation expressing what component realizes a function. To deduce the influence of an anomaly from the corresponding function or behavior in the flow structure, the influence on each function state when its input or output flow changes is interpreted as shown in Table 2. Propagating the influence in the flow structure, the change of flow at the associative link is known. The influence on the goal related to the associative link is estimated by the relational knowledge between the goal and the associative link (AL-G-knowledge). The influence is propagated to the function conditioned by the goal by the relational knowledge between the goal and the function (G-F-knowledge). Then, the influence in the upper flow structure is estimated. In this way, the influence is propagated over the functional model.

Each function state in the plant model is qualitatively evaluated by the values of plant instrumentation signals. Because function is defined as an interpreted behavior in terms of plant or component goals, the state of function can be evaluated by the states of behavior. Although a function state is usually related with some

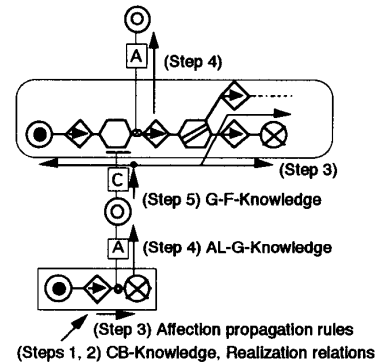

Fig. 4 Propagation of the influence by anomaly cause.

Table 2 Influence propagation rules of functions.

Function	Behavior interpretation rule
Source	If generation increases (decreases), then output increases (decreases).
Sink	If input increases (decreases), then the amount of flowing out increases (decreases).
Transport	1. If input increases (decreases), then output increases (decreases). 2. If output increases (decreases), then input increases (decreases).
Storage	1. If inputs increase (decrease), then storage increases (decreases) or outputs increase (decrease). 2. If an output increases (decreases), then storage increases (decreases) or other outputs decrease (increase).
Balance Conversion	1. If inputs increase (decrease), then outputs increase (decrease). 2. If an output increases (decreases), then other outputs decrease (increase).
Barrier	No influence is propagated.

instrumentation signals, a signal that is most relevant to the function (representative variable of function) is assigned beforehand to evaluate the state of function.

Figure 5 shows examples of representative variables of function. The left hand side figure shows that a heat exchanger is roughly modeled by the variables of  $H12$  (heat transfer rate between primary and secondary sides) and inlet and outlet flow conditions such as  $h1in$ ,  $W1in$ , and so on. The right hand side figure is a functional model of the heat exchanger by the MFM. The goal of this heat exchanger is to remove heat from the primary flow. The energy flow structure shown in the rounded rectangle means that the energy of the fluid at the inlet of the primary side is divided into two energy flows, that is, one for the energy of the fluid at the outlet, the other corresponding to the heat transfer rate. Because the primary and secondary fluids should continuously flow, two energy transport functions are conditioned by the two goals of primary flow and secondary flow, respectively. These goals are achieved by the two mass flow structures. For example, the first mass transport function in the mass flow structure to achieve the goal ( $G1$ ) expresses the primary flow at the inlet. The state of this function can be evaluated by a representative variable of the function, primary inlet flow rate ( $W1in$ ). Similarly, the state of the second mass transport function can be evaluated by the primary outlet flow rate ( $W1out$ ).

The qualitative evaluation results of function states by the influence propagation and plant instrumentation signals are compared for each anomaly cause. The anomaly cause that gives most similar function state patterns by the two evaluation methods is considered as the real anomaly cause. The total matching index  $f$  to measure the similarity is given from the matching index for each function  $x_i$  by

$$f = \sum x_i \quad (1)$$

where  $x_i$  is 1 when the qualitative evaluation values by the two methods are the same, -1 when they are different, and 0 when one of the two qualitative evaluation values does not change from the value at the normal operating condition.

## 6. DERIVATION OF POSSIBLE COUNTER ACTIONS

Possible counter actions are derived by the following three steps:

- (1) deduction of influence of the anomaly cause to plant functions

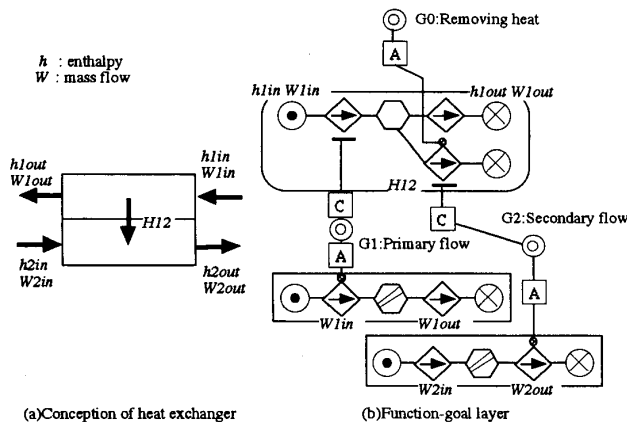

Fig. 5 Examples of representative variable of function.

and goals,

- (2) selection of goal or anomalous behavior to be recovered in the highest priority, and
- (3) finding possible counter actions to recover the achievement of the selected goal or anomalous behavior.

The algorithm to deduce the influence of anomaly cause is the same as that in identifying anomaly cause. A degraded goal or anomalous behavior to be recovered in the highest priority is selected by the following rules. If an influence on a goal or anomalous behavior is dangerous to the system by the D-knowledge, the goal or the behavior has a top priority. Otherwise, the higher goal in the means-end network expressed by the plant model has higher priority. Finally, the means-end network is reversely traced by requesting the change of each function's state and each goal's achievement to be able to recover the goal or anomalous behavior with top priority. If an operation is assigned to the function (from O-knowledge) whose flow should be changed, the operation is regarded as a possible counter action.

## 7. APPLICATION TO AN OIL REFINERY PLANT USING PLANT SIMULATOR

The effectiveness of the anomaly identification and counter action derivation techniques is demonstrated through applications to an anomaly case of an oil refinery plant. The anomaly cause is a degradation of naphtha extraction pump from the reflux drum. The calculated values by a plant simulator is assumed to be real plant data.

### Plant model

The components of the plant dealt with in the applications are desalter, various pumps, various heat exchangers, preflash drum, crude heater, main fractionator, reflux drum, and coolers.

The supplied crude is heated in heat exchangers and removed salt in the desalter. Then, gas and liquid phases are separated in the preflash drum. The gas phase is directly supplied into the main fractionator. On the other hand, the liquid phase is supplied into the main fractionator after heating by the crude heater. The main fractionator separates the desalted crude into top gas, productive ingredients of kerosene, light gas oil (LGO), heavy gas oil (HGO), and residue in the atmospheric pressure. The top gas is cooled by a cooler and is separated into flare and one product of naphtha. Each productive ingredient of kerosene, LGO, or HGO is further refined in the corresponding stripper under low-pressure environment by blowing steam.

A simplified plant model is built for the oil refinery plant after the desalter. To build the model of the function-goal layer representing intentional information, the authors first analyze the goals of each component and make sub-functional model for each component. Then, these sub-functional models are combined into a total functional model by considering the hierarchy of the goals of the components in the plant design intention.

### Identification of anomaly cause

In this anomaly identification, the following two anomaly causes are assumed to be given:

- (1) degradation of naphtha extraction pump, and
- (2) change of crude property to that of a lighter crude.

The identified anomaly cause is the former cause because the cause

gives a total evaluation index smaller than that of the latter cause.

#### Derivation of candidates of counter actions

The derived possible counter actions are compared with those given by operation experts of the oil refinery plant. By the anomaly cause of the pump degradation, the liquid level of reflux drum increases. The possible counter actions are derived to recover the liquid level.

Twelve possible counter actions are derived. These are

- (1) increase of the flow rate of naphtha extraction pump,
- (2) decrease of crude supply rate,
- (3) increase of the temperature of naphtha ingredient flowing into the reflux drum,
- (4) increase of top reflux flow rate,
- (5) increase of extraction rate of kerosene ingredient from the main fractionator, and so on.

On the other hand, experts of the plant suggest the following three counter actions:

- (a) check the operational condition of the naphtha extraction pump,
- (b) decrease of crude supply rate, and
- (c) decrease of the set point of top temperature of the main fractionator.

Although the derived counter actions are seemed to be too many by comparing the number of the suggested counter actions by experts, the derived counter actions cover the suggested counter actions. The derived counter actions of (1), (2), and (4) correspond to the suggested counter actions of (a), (b), and (c), respectively. The reasons of deriving many counter actions are no consideration of operational restrictions and no estimation of effects and side effects of a derived counter action in this derivation. In a near future, the SI will select reasonable number of derived counter actions by considering the controllability of each component expressed in operation manuals and quantitative effects of each counter action on plant future behavior.

#### 8. CONCLUSION

This paper describes the objectives, approaches, and current status of an intelligent information display agent, SI. The characteristic feature of the SI is to derive and display diagnostic information from functional viewpoint as well as from behavioral, operational, and structural ones in an anomalous plant situation. The algorithms to derive diagnostic information of anomaly identification and finding possible counter actions applying the qualitative reasoning to a functional model are presented. The derived diagnostic information is displayed in a graphical way and necessary graphs to understand plant situation and the derived diagnostic information are automatically shown. The applicability of the diagnostic techniques applied the qualitative reasoning is demonstrated through applications to an oil refinery plant using a plant simulator.

As mentioned in this paper, the SI works as an intelligent agent in a distributed agents system[5] communicating especially with the interface agent, IA, and the ontology server, OS. The authors are now transferring the display and inference programs from a Smalltalk-80[11] that was used in the previous studies to Java (JDK 1.1.7) and implementing the SI in the agents system. As other future works,

- (1) the subsystem to select a suitable counter action will be implemented using a fast future prediction code generated by an intelligent modular simulation system[9], and
- (2) display control subsystem will be developed to flexibly indicate diagnostic information according to the operators' attention.

#### 9. ACKNOWLEDGMENTS

This paper was prepared under an Entrustment Contract with the Laboratories of Image Information Science and Technology (LIST) from the New Energy and Industrial Technology Development Organization (NEDO) in concern with the Human Media Research and Development Project under the Industrial Science and Technology Frontier (ISTF) program of the Ministry of International Trade and Industry (MITI) of Japan. The authors would like to appreciate the project leader, Prof. R. Mizoguchi, to lead the project. The authors express our thanks to Mr. M. Tokunaga and Mr. H. Makino of Nippon Mitsubishi Oil Corporation for their kind offer of simulated data. The authors also appreciate other members in the project committee for their useful discussions.

#### 10. REFERENCES

- [1] I. Kuroda, Human Characteristics in Emergency Situations and Man-Machine Systems, Automation, Vol. 22, No. 1, 1977, pp.43-48 (in Japanese).
- [2] H. Kaiho and F. Tanabe, Human Errors, Shinyosha, 1996 (in Japanese).
- [3] K. Vicente and J. Rasmussen, The Ecology of Human-Machine System II, *Ecological Psychology*, Vol. 2, 1990, pp. 207-249.
- [4] W. B. Rouse, Design for Success, John Wiley & Sons., 1991.
- [5] R. Mizoguchi, A. Gofuku, S. Yamauchi, and Y. Sakashita, Development of Human Interface for the Next Generation Plants, *Systems, Control and Information*, Vol. 42, No. 5, 1998, pp. 244-252 (in Japanese).
- [6] A. Gofuku and Y. Tanaka, Development of an Operator Advisory System: Finding Possible Counter Actions in Anomalous Situations, *Proc. Fifth Int. Workshop on Functional Modeling of Complex Technical Systems*, 1998, pp. 87-97.
- [7] A. Gofuku, K. Adachi, and Y. Tanaka, Finding out Counter Actions in an Anomalous Plant Situation Based on Functions and Behavior, *Trans. the Institute of Systems*, Vol. 11, No. 8, 1998, pp. 458-465 (in Japanese).
- [8] A. Gofuku and Y. Tanaka, Application of a Derivation Technique of Possible Counter Actions to an Oil Refinery Plant, *Proc. IJCAI Fourth Workshop on Engineering Problems for Qualitative Reasoning*, 1999, to appear.
- [9] A. Gofuku and Y. Tanaka, A Combination of Qualitative Reasoning and Numerical Simulation to Support Operator Decision in Anomalous Situations, *Proc. IJCAI Third Workshop on Engineering Problems for Qualitative Reasoning*, 1997, pp. 19-27.
- [10] M. Lind, Modeling Goals and Functions of Complex Industrial Plants, *Applied Artificial Intelligence*, Vol. 8, No. 2, 1994, pp. 259-283.
- [11] ParcPlace-Digitalk Inc., "VisualWorks 2.0J User's Guide", 1996 (in Japanese).